

**Operating manual  
for  
automatic – spray valves  
GF / 4 and  
GF / 4 HVLP**



Read this manual carefully before installing, operating or servicing this equipment.  
Keep always handy for further use.

# 1 Introduction

The automatic spray valves **GF/4** resp. **GF/4 HVLP** are designed and constructed for application of release agents, oils, colours, paints, glues and other fluids. Depending on position of regulation of spray jet, this spray valve sprays from round- to 90° flat spray. Depending on viscosity of fluid, the application can be adjusted individually via nozzle dimension, atomizing air pressure, material pressure and the continuously adjustable spray jet regulation. The supply of atomizing air (2x), control air and material should be done via four hoses. Spray valves are precision tools. Always keep clean and observe minimum instructions to maintain a long useful life of the valve.

## 2 Safety

### 2.1 Duties of the user

- The user must read this service manual carefully before performing any operations.
- Application and service operations should not be carried out if the user is not absolutely sure of the purpose and consequence of the operations.

### 2.2 Definitive Use

The automatic spray valve **GF/4** resp. **GF/4 HVLP** is a pneumatically controlled needle valve. It is suitable for continuously or intermittent use. It is not suitable for spraying aggressive fluids like acid, alkaline solutions, cleaning agents, chemicals etc.. In case of doubt, please contact the manufacturer.

### 2.3 Warning against danger

This operating manual warns users of operations which may put their health at risk. The warnings are indicated by combinations of text and symbols corresponding to the different danger classes.

#### **WARNING!**

Signs a possible dangerous situation.  
If you don't avoid, *death or severe injuries* can follow.

#### **CAUTION!**

Indicates a situation which may be dangerous.  
Failure to heed the caution may result in *personal injury*. This indication is also used where material damage is possible.

#### **IMPORTANT!**

Indicates tips for usage and other helpful information.

## 3 Function Description

The automatic spray valve **GF/4** resp. **GF/4 HVLP** is pneumatically controlled: air open; spring return. The spraying material is to be fed to the valve via pressure tank or pump. The separate controlled atomizing air (for middle hole and cone holes) atomizes the material to a spray jet. Depending on position of continuously adjustable spray jet regulation, the valve sprays from a round- up to a 90° flat spray.

## 4 Installation

The automatic spray valve **GF/4** resp. **GF/4 HVLP** can be installed in any position. For solid attachment a thread (M10) within valve body is available. Optionally a clamp (drawing no.: 13.0) is available. Vibration of the equipped machine to the valve should be limited as far as possible. Vibrations of the valve caused by fast intermitting cycles require solid and massive installation.

### 4.1 Hose connection and assembly

Connect hoses for atomizing air (2x) and control air to separately control valves (pressure reducers and solenoids). Then fluid hose to material pressure tank or other means of feeding fluid as under:

- 2 x atomizing air, marked with "Z" (draw.-no.: 5.0, hose blue):
  - ➔ to 2/2 way solenoid
- control air, marked with "S" (draw.-no.: 5.0, hose black):
  - ➔ to 3/2 way solenoid
- fluid, marked with "M" (draw.-no.: 7.0, hose transparent):
  - ➔ to feeding device

OPTIONAL:

- material circulation, (draw.-no.: 7.0 instead of 6.0, hose transparent):
  - ➔ back to feeding device

### 4.2 Operating instructions

#### CAUTION !



Never point the spray jet against persons. Wearing eye protection is strongly recommended. Spraying procedures cause noises depending on the used pressure. If necessary, wearing of ear protection is recommend.



#### WARNING !

Danger caused by combustibile and noxious spraying material. Safety instructions on fluid can and material data of fluid manufacturer must definitely be observed.

The automatic spray valves of series **GF/4** and **GF/4 HVLP** need 3 – 6 bar control air pressure. Atomizing air pressure and material pressure should be as low as possible. In any case, please observe the regulations of the professional/trade association having liability for industrial safety and insurance.

When you are certain, that fluid pressure stands up to the nozzle, actuate 2/2 way solenoid for atomizing air. After that actuate 3/2 way solenoid for control air. This way you receive so called "pre-air" prior to opening fluid flow. After each cycle solenoids are to actuate in reverse order, so you will still have "purging-air" after needle has closed nozzle and fluid flow was stopped. This prevents fluid to form out drops instead of being atomized.

Set atomizing air pressure and fluid pressure according to required spray droplet sizes. Two separate pressure reducers must be available. Intermittend use as well as continuous use is possible. Maximal 30 cycles per second are possible (under optimal working conditions).

#### IMPORTANT !



The quantity of fluid flow can be adjusted by the regulating knob (draw.-no.: 12.0).  
Turning this knob in anti-clockwise turn = more fluid flow  
Turning this knob in clockwise turn = less fluid flow  
Do not over-tight the regulating knob.

#### IMPORTANT !



To avoid damages to nozzle and needle adjust decrease of fluid flow (turning regulating knob 12.0 clockwise) only when fluid is emitted from the nozzle. This is the only way to observe the steady reduction of fluid flow until an absolute stop of fluid. Going on to turn the regulating knob clockwise would at once push the needle into the nozzle to such an extant that both parts could be damages.

It is harmless to leave fluid within the valve (no connection to outside air), if system stays under pressure.

## 5 Repair and Maintenance

Before starting maintenance or repair work, ensure that all air operated tools are disconnected from the air supply.



### **WARNING !**

Danger caused by combustible and noxious spraying material. Safety instructions on fluid can and material data of fluid manufacturer must definitely be observed.



### **WARNING !**

Before opening the spray valve it has to be disconnected from the air and fluid supply. Otherwise ejected elements can cause danger.

The automatic spray valve **GF/4** resp. **GF/4 HVLP** is a high precision tool. Always keep clean and observe minimum instructions to maintain a long and useful life of valve. We recommend lubricating moveable parts regularly, and greasing threads, especially the nozzle threads, when replacing or cleaning the nozzle. It is recommended to use clean and filtered application fluid only. Also atomizing air should be clean. Control air should be slightly oiled.

### 5.1 Cleaning

To clean valve, spray solvent until pure solvent leaves nozzle. Do not submerge entire valve in solvent. At longer working interruptions it is advisable to clean air cap and nozzle by putting these parts only into solvent. If necessary use a soft brush. Moving parts and threads should always be greased slightly. The spray valve should be cleaned using an appropriate thinner. To clean small drill holes, use our special nozzle cleaning needles.

These spray valves are high precision tools. Always keep clean and observe minimum instructions to maintain a long and useful life of valve.

We recommend lubricating moveable parts regularly, and greasing threads, especially the nozzle threads, when replacing or cleaning the nozzle.

### 5.2 Possible case of failure: Needle sticks

- Check, if sufficient control / operating air is supplied (3 - 6 bar).
- Check, if o-ring (9.1) is in proper order.
- Check, if needle is dirtied by f.i. glue residues or sticks within needle gasket (8.1 / 8.4) or within nozzle.
- Check, if minimum of travel of needle is set.

### Trouble shooting.

- If drops form on the nozzle, either needle or nozzle is worn out and should be replaced. Or needle is not closing properly f.i. because particle residues within nozzle.
- If there is an uneven or not steady spray jet, make sure that nozzle is screwed in tight. Other reason could also be dirt residue within air cap.

### 5.3 Changing the nozzle set



### **IMPORTANT!**

Nozzles, gaskets and gasket seats can be damaged. Do not use metallical aid to remove and insert those parts.

A nozzle set includes needle (9.0), nozzle (2.0) and air cap (1.0).

If nozzle size is to be changed, always change all these three parts. Change the complete set also when only one of the parts is defect.

Disconnect all air operated tools from the air supply.

- Screw out closing screw (11.0).
- Pull out needle spring (10.0) and needle (9.0).
- Take off air cap (1.0).
- Screw out nozzle (2.0), please observe that needle is never under spring pressure.

Reassemble in reverse order.

To prevent damage to the needle seat during replacement, the needle (9.0) must only be inserted into firmly installed nozzle.

## 5.4 Changing needle gasket



### IMPORTANT!

Gaskets and gasket seats can be damaged. Do not use metal aid to remove and insert those parts.

Before starting maintenance or repair work, ensure that all air operated tools are disconnected from the air supply.

- Screw out closing screw (11.0).
- Pull out needle spring (10.0) and needle (9.0).  
Then unscrew retainer (8.0).

After unscrewing retainer (8.0) all o-rings and gaskets (8.1 / 8.2 / 8.4) can be changed. The o-ring (9.1) can be changed from the needle piston.

Reassemble in reverse order.

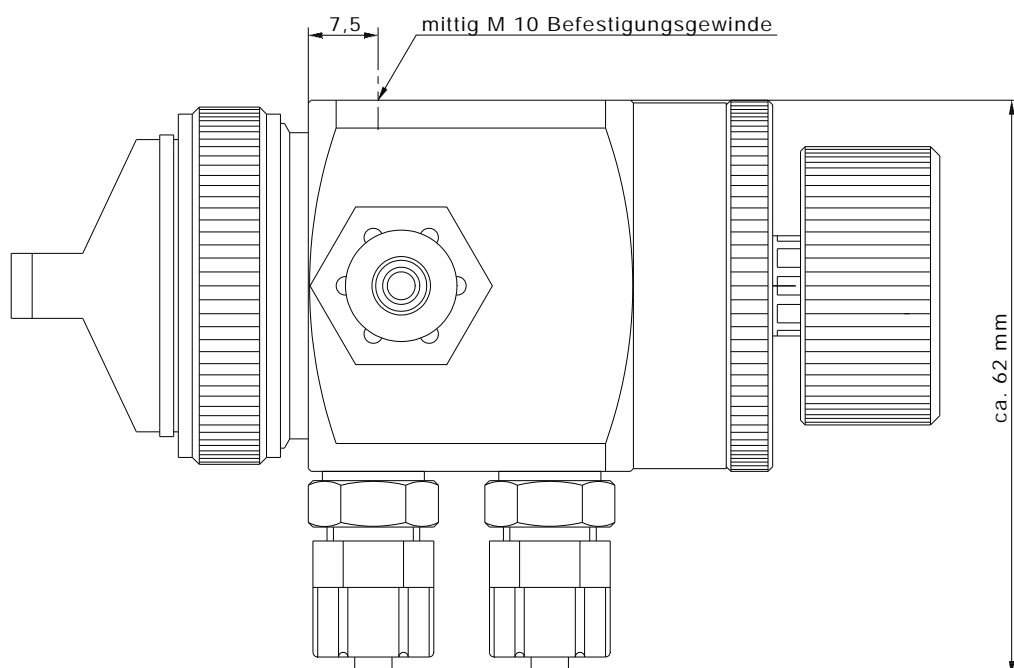
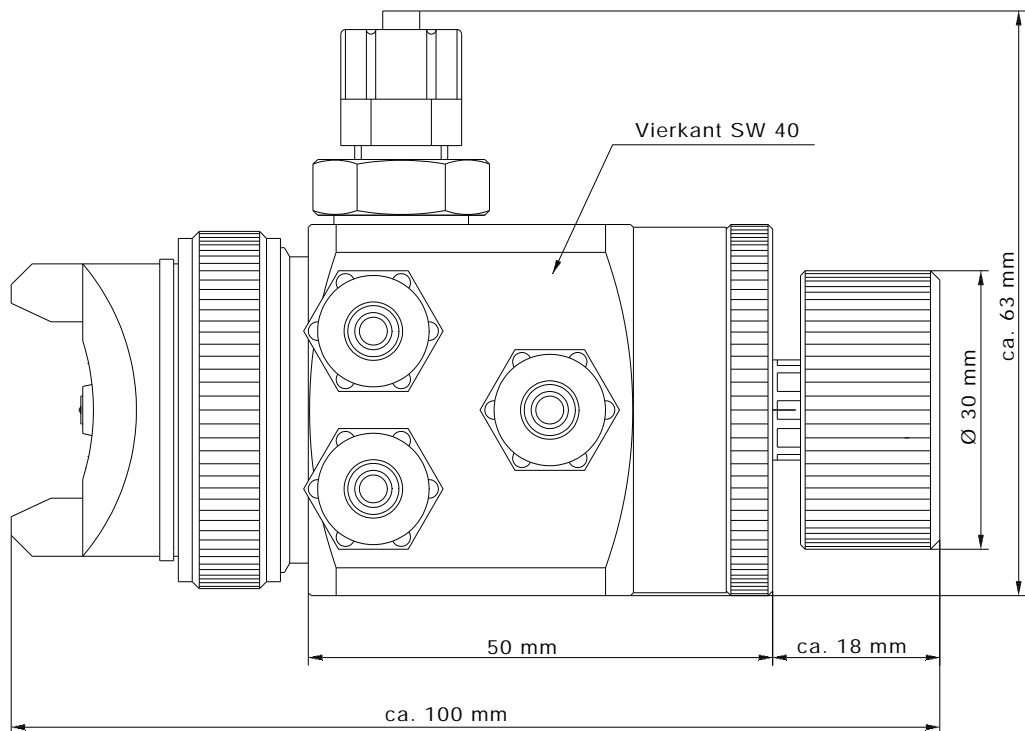

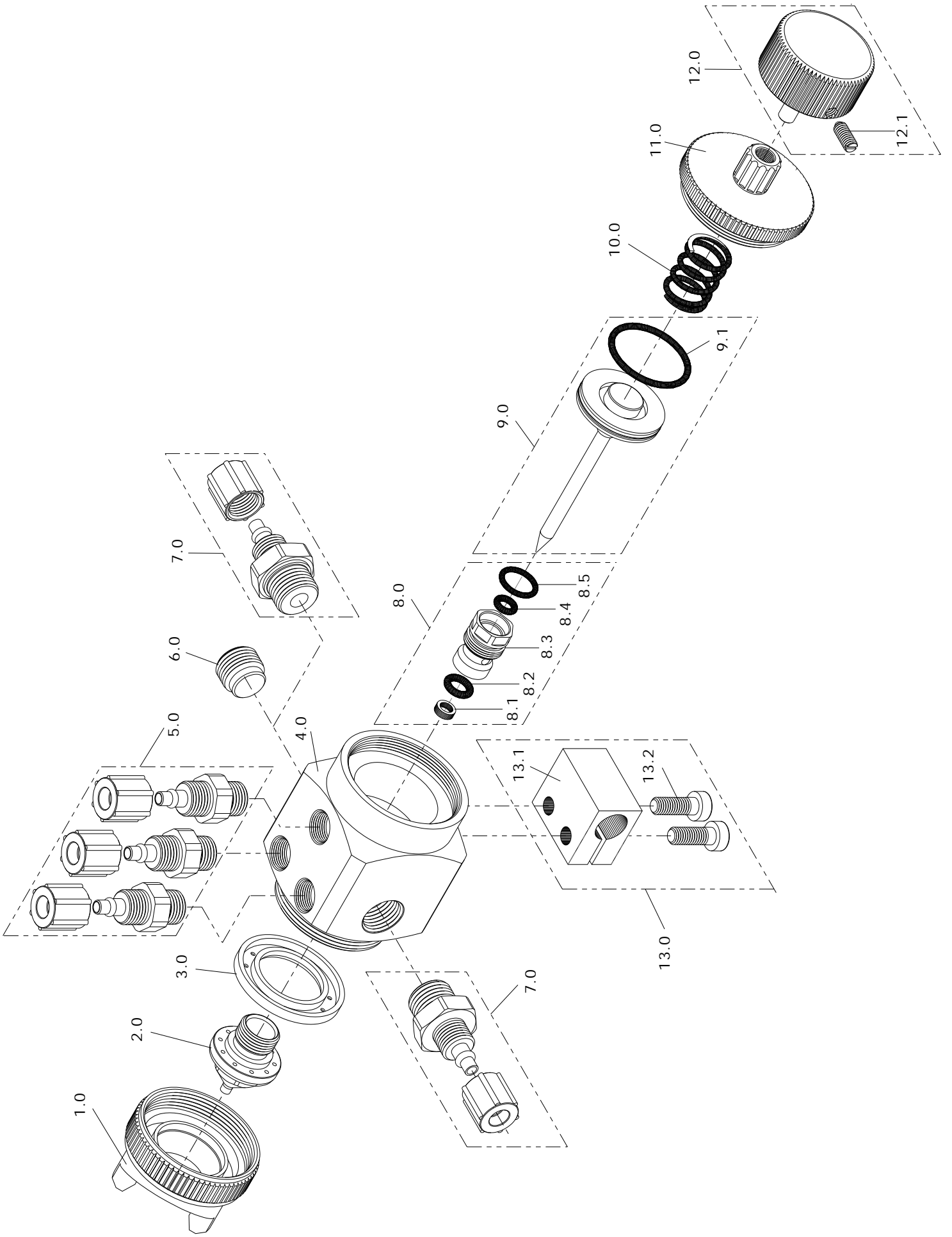

## 6. Spareparts

draw.-no.	part no.:	quantity	description
1.0	*	1	aircap (standard) and aircap (HVLP)
2.0	*	1	nozzle, stainless steel, 21 x 25,5mm, SW13
3.0	310052	1	air distribution plate, ø 33 x 3mm
4.0	510349	1	valve body GF4, 52 x 40 x 40mm
4.0	510352	1	valve body GF/4 HVLP, 52 x 40 x 40mm
5.0	*	3	screw with nut
6.0	610102	1	screw, stainless steel 1/4"
7.0	*	1 / 2	screw with nut
8.0	810157	1	retainer, complete, SW 11 x 17mm / 1.4404
8.1	640029	1	gasket (stepseal 4 x 8,9 x 2,2)
8.2	640375	1	o-ring 5 x 2 / Viton®
8.3	810156	1	retainer, SW 11 x 17mm / 1.4404
8.4	640032	1	o-ring 3,68 x 1,78 / Viton®
8.5	640046	1	o-ring 9 x 1,5 / Viton
9.0	*	1	needle, complete, stainless steel
9.1	640241	1	o-ring 21,95 x 1,78 / Viton®
10.0	820078	1	spring 1,5 x 20,5mm
11.0	320322	1	closing screw, 40 x 20,5mm
12.0	800052	1	ratchet assembly, complete, ø 30 x 29mm
12.1	820003	1	elastic thrust piece M4 x 9mm
12.2	320323	1	regulating knob, ø 30 x 29mm
13.0	910015	1	clamp, complete, 21,5 x 25 x 15mm
13.1	910014	1	clamp 21,5 x 25 x 15mm
13.2	610042	2	screw DIN 6912 M5 x14

\* Please find part numbers on page 8.

When ordering nozzle sets please specify dimension.

Available dimensions: 0,3 / 0,5 / 0,8 / 1,0 / 1,2 / 1,3 / 1,4 / 1,5 / 1,7 / 1,8 / 2,0 / 2,5 / 3,0 / 3,5mm Ø  
nozzle set = needle, nozzle and air cap.

If nozzle size is to be changed, always change all these three parts. Change the complete set also when only one of the parts is defect.

## 7. Technical data

measurements : approx. 63mm x 62mm x 100mm length  
weight : approx. 400g  
control air pressure : min. 3 – max. 6 bar  
atomizing air pressure : as required  
material pressure : max. 10 bar

Special designs on request. Technical alterations reserved. June 2009.

## 6.1 part numbers for needles, nozzles and air caps

<b>*needles</b>		
draw.-no.	part-no.	description
9.0	110923	0,3 mm
9.0	110924	0,5 mm
9.0	110925	0,8 mm
9.0	110926	1,0 mm
9.0	110927	1,2 - 1,4mm
9.0	110930	1,5 mm
9.0	110931	1,7 mm
9.0	110932	1,8 mm
9.0	110933	2,0 mm
9.0	110934	2,5 mm
9.0	110935	3,0 mm
9.0	110936	3,5 mm

<b>*nozzle</b>		
draw.-no.	part.-no.	description
3.0	210155	0,3 mm
3.0	210156	0,5 mm
3.0	210080	0,8 mm
3.0	210081	1,0 mm
3.0	210082	1,2 mm
3.0	210083	1,3 mm
3.0	210084	1,4 mm
3.0	210085	1,5 mm
3.0	210086	1,7 mm
3.0	210087	1,8 mm
3.0	210088	2,0 mm
3.0	210089	2,5 mm
3.0	210090	3,0 mm
3.0	210091	3,5 mm

<b>* aircap</b>		
draw.-no.	part-no.	description
1.0	310053	for nozzle 0,3 - 1,0 mm
1.0	310054	for nozzle 1,2 - 1,4 mm
1.0	310055	for nozzle 1,5 - 1,8 mm
1.0	310056	for nozzle 2,0 mm
1.0	310057	for nozzle 2,5 mm
1.0	310058	for nozzle 3,0 mm
1.0	310059	for nozzle 3,5 mm

<b>* aircap HVLP</b>		
draw.-no.	part-no.	description
1.0	310066	for nozzle 0,3 - 1,0 mm
1.0	310067	for nozzle 1,2 - 1,4 mm
1.0	310068	for nozzle 1,5 - 1,8 mm
1.0	310069	for nozzle 2,0 - 2,5mm
1.0	310070	for nozzle 3,0 mm

<b>* screw (for air)</b>		
draw.-no.	part-no.	description
5.0	220022	screw with nut SW 13x28mm / 1/8" - 6/4 (standard)
5.0	220243	screw with nut SW 13x28mm / 1/8" - 8/6

<b>* screw (for material)</b>		
draw.-no.	part-no.	description
7.0	220023	screw with nut SW 17 x 30,5mm / 1/4" - 6/4 (standard)
7.0	220298	screw with nut SW 17 x 30,5mm / 1/4" - 8/6