

Operational Instructions

Glue Applicator MS 200

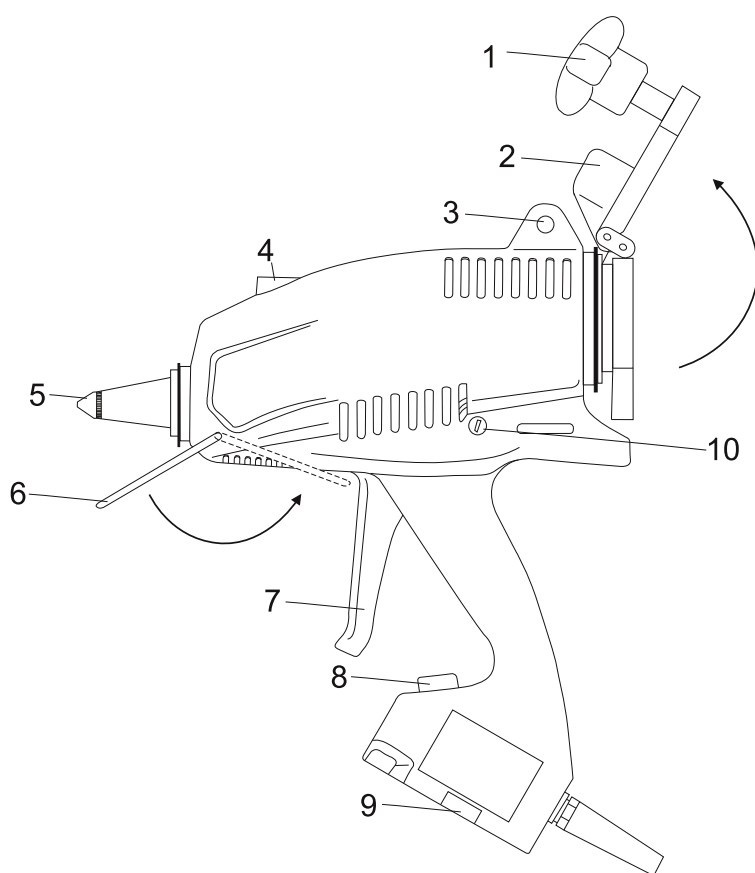

Table of Contents

Product Description	1
General Safety Instructions	2
Safety Measures to be taken during Operation	3
Start-up and Control	4
Cleaning and Maintenance	6
Trouble-Shooting	7
Environmental Protection	8
Additional Information	8
CE Declaration of Conformity	9
Spare Parts	10
Technical Data	11



No. Denomination

- 1 Star Grip
- 2 Lid
- 3 Plug
- 4 Screw for Temperature Regulation
- 5 Nozzle
- 6 Wire Stand
- 7 Trigger
- 8 On/Off Switch
- 9 Magnet
- 10 Screw for Adjusting Trigger

Product Description

Dear customer,

the glue applicator you purchased will help you to glue parts together more easily and more rapidly. To ensure an optimum usage of the glue applicator we recommend that you read these instructions thoroughly before using the applicator for the first time.

The following illustration show where to find the serialnumber of the applicator:

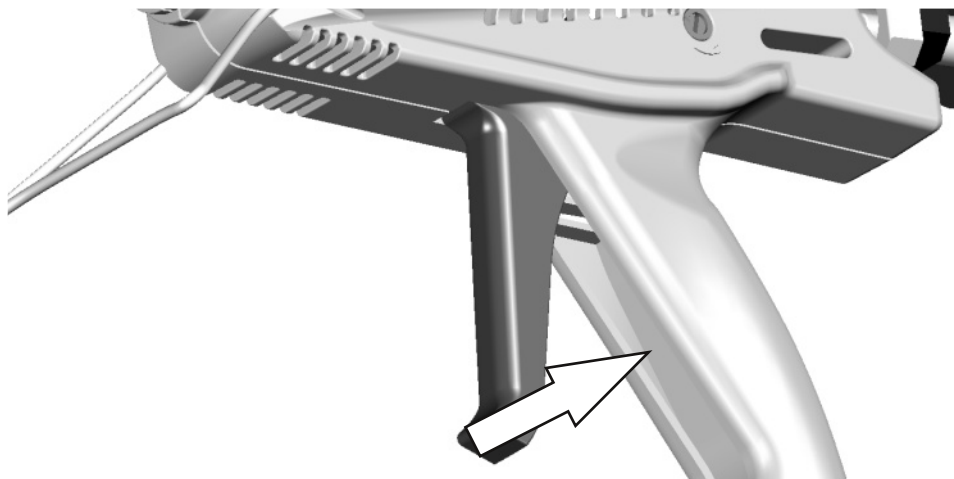

Intended Use

The applicator works with non reactive hot-melt glue which is dispensed by a mechanical conveying system. Therefore, this glue applicator should only be used by qualified persons who have been familiarized with the proper use and the safety precautions. Handling the applicator properly will avoid unnecessary accident hazards and problems.

Bodily injury or material damage caused by not using the glue applicator as intended shall not be the manufacturer's, but the user's responsibility.

General Safety Instructions

Care and Diligence of the User

The glue applicator has been designed and fabricated in conformity with the applicable harmonized standards and additional technical specifications. So, it is state of the art and ensures maximum safety. This safety, however, can only be achieved in the operational practice, if all the necessary measures are taken. The user of the equipment shall be obliged to plan these measures and to make sure that they are taken.

In particular, the user shall ensure that

- the applicator to be used is in good working order
- the personal protective equipment (protective gloves, safety goggles) required for the operating personnel is available and used
- the operating instructions are in legible condition and available to the operator
- only sufficiently qualified and authorized personnel operates and maintains the applicator
- this personnel is regularly instructed in the applicable regulations of operational safety and environmental protection and knows the operating instructions and, in particular, the included safety instructions.

Making the Information available

This operating manual shall always be kept at the place of operation of the applicator. Be sure that all persons handling the applicator can consult the instructions at any time. In addition to this operating manual, there must be available instructions regarding legal and other mandatory regulations relating to accident prevention and to relevant requirements of the employers' liability insurance association.

Safety Symbols

This operating manual gives concrete safety instructions to alert the user to remaining unavoidable hazards. These hazards imply dangers to
persons
product and equipment

Meaning of the Symbols used in Manual and on Applicator



This symbol indicates that there is, above all, danger to persons, but also to equipment and material



Caution: hot surface! Accident Prevention Regulation VBG 125 – W26 Hot surfaces such as machine parts, tanks or materials, but also hot liquids cannot always be perceived. The utmost caution is advised when this symbol is attached to a component. Wear protective gloves whenever you have to touch hot surfaces.



To avoid accidents lay the cables so that they will not cause any risk of stumbling.



Wear protective gloves and safety goggles whenever you work with the applicator.



Safety Measures to be taken during Operation

The equipment must only be used by trained, instructed and authorized persons. These persons must have read the operating instructions and be able to work accordingly. Before using the applicator, check it for visible damage and make sure that it is only used when in proper and safe condition. Notify detected defects to your superior immediately.

Safety Instructions for the Operation of the MS 200 Hot-Melt Glue Applicator



Wear protective gloves and safety goggles whenever you work with the applicator.



Avoid accidents by stumbling – Lay all cables, hoses and conducts so that they will not cause any risk of stumbling. For this, install cable ducts and bridges.



Only fill the tank up to 1,5 cm (~0.6 inch) under the upper rim.

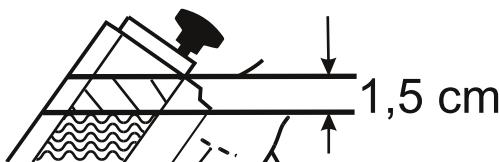

Never exceed the operating temperature of the hot melt. This temperature is indicated in the technical datasheet of the hot melt. Overheating may lead to decomposition which may affect the health of the user as well as the operability of the applicator.

Once the applicator has warmed up, nozzle and lid are very hot.

Never start working before fitting a nozzle first.

Only replace nozzle when applicator is warmed up.

Unplug the connecting cable, before replacing a nozzle. Warning: risk of burns! When a nozzle is replaced, liquid glue might leak out.

Never bring the hot nozzle into contact with the cable.

Never direct the glue jet towards people.

When your skin got into contact with hot glue, cool it with cold water immediately. Do not try to remove the hot-melt from the skin first. If necessary, consult a doctor. When hot adhesive got into your eyes, immediately cool them under running water for about 15 minutes and consult your doctor at once.

Always deposit the glue applicator on the wire stand or the respective plate destined for this purpose.

Do not lay the applicator on its side.

Do not hold nozzle top upward for too long. If you do hold it upward for too long, hot-melt will reach the lid and might flow out when the applicator is opened the next time.

Do not carry out overhead work.

Stop using the equipment, if the casing is damaged due to shock, breakage or heavy wear.

Do not feed solvents or paraffin. Risk of explosion!

Start-up and Control



Avoid accidents by stumbling – Lay all cables, hoses and conducts so that they will not cause any risk of stumbling. For this, install cable ducts and bridges.



Wear protective gloves and safety goggles whenever you work with the applicator.



Never direct the glue jet towards people!

Never lay the hot-melt applicator on its side.



Do not hold the nozzle top upward for too long.

Do not carry out overhead work.

Do not start working, before fitting a nozzle first.

Only replace nozzle when applicator is warm.

Only open the lid when the applicator has warmed up.

Do not overcharge the applicator; only fill it up to 1,5 cm (~0.6 inch) under the rim.

Stop using the equipment, if the casing is damaged due to shock, breakage or heavy wear.

The glue applicator must only be used/applied for its intended purpose. Please read the chapter „General Safety Instructions“. If it is not used as intended, this may cause bodily injuries or equipment damages. Disregard of the safety instructions for the use of the applicator may lead to serious burns.

Switch Applicator on/off

An illuminated on/off-switch indicates that the applicator is switched on. Press the switch in order to turn the applicator on or off.

Minor leaking while the applicator is warming up is due to the hot-melt expanding in the nozzle and heating chamber.

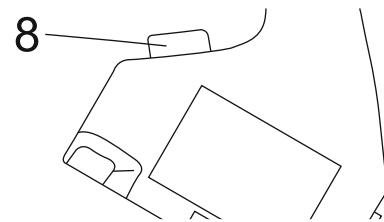

Adjust Temperature

The MS 200 glue applicator is factory-set to 200 °C. The temperature is continuously adjustable at the upper side of the applicator, turning the adjusting screw with a screw driver. The right-end stop is the maximum temperature of 200 °C. In order to lower the working temperature, turn the adjusting screw counter clockwise.

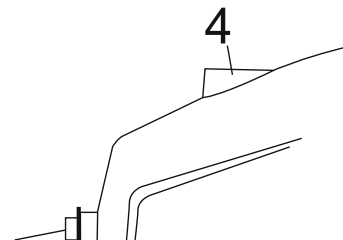

Adjusting the trigger

The adjustment of the trigger has influence on the lever stroke and on how much glue can be dispensed at once. A screwdriver can be used to turn the adjustable screw on the left side of the applicators' casing. The longer the lever stroke, the more glue can be dispensed at once and vice versa.

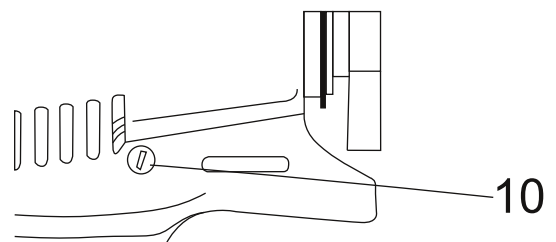

Start-up and Control

Loading Hot-Melt

The MS 200 glue applicator must only be used to dispense non-reactive hot-melts. Never feed other materials. The hot-melt glue applicator is capable of working with all non-reactive hot-melt types which are designed for working temperatures of up to max. 200 °C.

After the end of the heat-up period (approx. 5 min.), open the lid by turning the star grip counter clockwise.

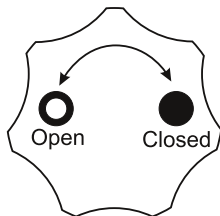

Load granulate up to 1,5 cm (~ 0.6 inch) under the lower rim of the feeding opening. Open the lid by turning the star gripe counter clockwise

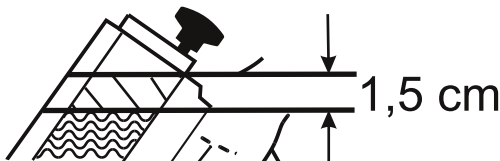

Shut the lid and allow the applicator to melt the glue.

Applying Hot-Melt

The adjustment of the trigger influences the output quantity and the lever stroke. The trigger can adjusted with a screw driver at the "Screw for Adjusting Trigger" on the left casing side. The longer the lever stroke, the more glue can be dispensed with one stroke and vice versa.



Wear protective gloves and safety goggles whenever you work with the applicator.



Never start working before fitting a nozzle first.

Never direct the glue jet towards people!



Do not start working before the glue has molten. Badly molten glue is thick and it needs a lot of force to press it off the applicator. Doing so would damage the applicator.

Always deposit the glue applicator on the wire stand or the respective plate destined for this purpose.

The glue applicator must not be laid on its side.

Do not open the lid before the applicator has warmed up.

When your skin got into contact with hot glue, cool it with cold water immediately. Do not try to remove the hot-melt from the skin first. If necessary, consult a doctor. When hot adhesive got into your eyes, immediately cool them under running water for about 15 minutes. Consult your doctor at once!

Make yourself familiar with applicator first. Apply a little glue in varying forms on a piece of paper or cardboard; for example dots and beads. Always keep the working temperature of the specific hot-melt glue. This temperature is indicated in the technical datasheet of the hot-melt glue.

The quantity to be applied is determined by pulling the trigger: the more you pull the more glue flows out.

Start-up and Control

Picking up/put down the Applicator

The MS 200 has a wire stand which is used to put down the applicator. Reka recommends folding in the wire stand when working with the applicator.

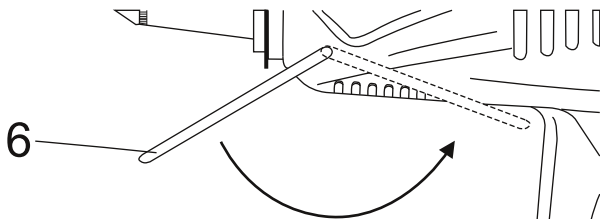

Furthermore, the MS 200 can be put down on magnetic surfaces by using the magnetic foot. In this case the wire stand is not needed and can stay folded in.

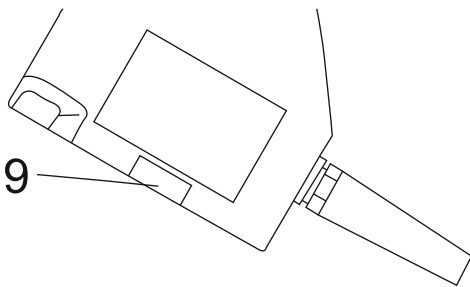

Replacement of Nozzles



Warning: risk of burns! When your skin got into contact with hot glue, cool it with cold water immediately. Do not try to remove the hot-melt from the skin first. If necessary, consult a doctor. When hot adhesive got into your eyes, immediately cool them under running water for about 15 minutes. Consult your doctor at once!



For your own safety: wear protective gloves and safety goggles when you replace nozzles.



Always unplug the applicator before replacing a nozzle!

Only replace nozzles when the glue applicator is warm (instrument temperature 60 – 80 °C) and empty. Replacing a nozzle when the applicator is cold may damage the equipment. Replacing the nozzle when the applicator is too hot, causes liquid glue to flow out. The melting range as well as the melting point of the used glue may be taken from the technical datasheet of the respective glue.

Cleaning and Maintenance

Never fill soiled glue into the melting tank. If you observe all advices given in the operating manual, the glue applicator does, normally, not need cleaning. The non-reactive glue contained in the applicator will remelt and can be used for gluing again. The working temperature of the respective glue may be taken from the technical datasheet which can be procured from the producer of the glue. This temperature must not be exceeded, otherwise the glue may coke in the glue applicator. Hot-melts on a polyamide basis are particularly sensitive.



Never clean the applicator with solvent, benzine, benzene, toluene, acetone, turpentine, etc. risk of explosion!

If the applicator is used very often, we recommend having it maintained regularly. For this, fix a date with our service department.

Trouble-Shooting

List of possible fault indications and assistance in trouble-shooting

In case of damage, send the glue applicator to Reka, indicating type and serial no. of your applicator. We shall not be responsible for any repair made by yourselves.

Fault	Possible cause/operating error	Measures to be taken
No or too little glue comes off though the heat-up time has been kept exactly	Clogged nozzle Temperature too low	Unscrew the nozzle, clean or replace it Check temperature
The glue is too fluid or too thick	Applicator temperature too high or too low	Check the temperature
Glue leaks out of nozzle	Clogged nozzle	Unscrew the nozzle, clean it carefully or replace it. Unscrew the nozzle at operating temperature; wear gloves (risk of burns)
The applicator does not heat up	The applicator is switched off	Is the applicator properly connected to power?

Environmental Protection

Never throw electric tools in the domestic waste. According to the European directive 2002/96/EC for used electric and electronic devices and according to national regulations, used electric tools must be collected separately and treated in an environmentally compatible way for re-use.

Reka packing material can be recycled completely.

Please take instructions for the disposal of hot-melt glues and hot-melt cartridges from the respective safety datasheet.

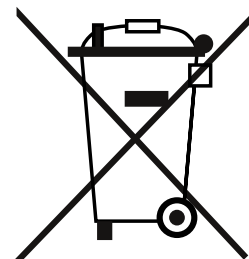

Additional Information

**RHEOLOGICAL LIMITED
UNIT 6, ST MARGARETS BUSINESS PARK
MOOR MEAD ROAD
TWICKENHAM
MIDDLESEX
TW1 1JN
UNITED KINGDOM**

**TEL: 0044-207-837-1289
FAX: 0044-208-744-2222
EMAIL: sales@rheological.co.uk
WEB: www.rheological.co.uk**

CE Declaration of Conformity

Product: Hot-Melt Glue Applicator

Type: MS 200

This is to certify that the above applicators in the design marketed by us are in conformity with the following EC directives:

U-ntil 15-01-2007: 73/23/EEC, from 16-01-2007: 2006/95 EC
until 19-07-2009: 91/368 EEC, from 20-09-2009: 2004/108 EC
until 28-12-2009: 89/336 EEC, from 29-12-2009: 2006/42 EC
2002/95/EC

The following standards have been applied:

IEC CISPR14
IEC 60335
IEC 60204
IEC 61000



Christa Armbruster

Management Purchasing and Production

Spare Parts

Lid MS 200

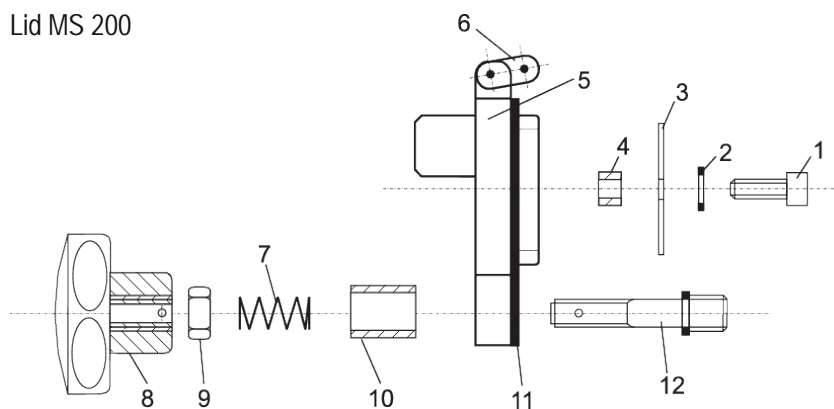

No.	ArticleNo.
1	2801
2	2800
3	2819
4	2820
5	3367
6	2617
7	2718
8	2613
9	3665
10	2885
11	2603
12	2911
13	2073
14	2075
15	2006
16	2933
17	3803

Nozzle MS 200

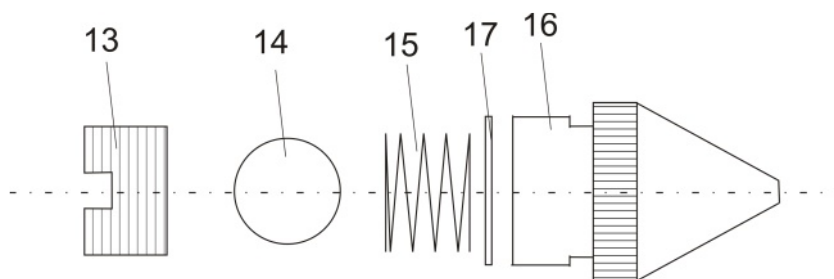

Technical Data

	MS 200
Article Number	5570, 5571
Weight	1220 g
Power supply	230 V / 50 Hz
Power consumption	600 Watt
Current consumption	2,6 A
Degree of protection	I
Class of protection	IP 30
Temperature control	Thermostat
Temperature limitation	Temperature controller
Operating temperature	20 - 200 °C / 70 – 390 °F
Temperature constancy	+ - 5 °C
Heat-up time	approx. 5 min.
Gross tank capacity	250 ml
Conveying system	Mechanics
Length of electric cable	1,8 m
Recommended melts	Hot-melt granulate, pillows and 43mm (1.7") Sticks